

ENGR 1125 – Introduction to Sensors, Instrumentation and Measurement

September 6, 2015

During your first week in lab, you will receive some basic supplies that will allow you to prototype and power your circuits for the rest of the semester. You will receive a solderless breadboard. You will also receive a printed circuit board (PCB) and all of the components required to populate it. The PCB plugs into the power distribution rails of your solderless breadboard and provides you with ground, a 5-V power supply rail, and two 2.5-V reference rails. These items will be yours to keep; they should prove useful to you beyond this course. We expect that you will bring them with you to lab each week along with your Analog Discovery and your laptop.

If you have not yet reviewed the soldering tutorials that we asked you to review before coming to lab, please review them before you begin. Obtain your materials, the bare PCB, and all of the components you need to assemble the board. Some of the components are quite small, so you might want to obtain those when you are actually able to get time on one of the soldering stations. To assemble your PCB, we recommend proceeding as follows:

1. Using the attached component map and assembly photos as a guide, solder all of the surface-mount components, paying careful attention to the orientation of the light-emitting diode (LED).
2. Solder the strip header pins using an old solderless breadboard as a jig to hold the pins in the proper place.
3. Solder the USB connector and the barrel jack power connector to the board.
4. Clean any flux residue off the board with isopropyl/ethyl alcohol and an old toothbrush.

The basic procedure for soldering each surface-mount component with a soldering iron is as follows:

1. Using a felt-tipped flux pen, apply some (a small amount) of liquid flux to the component's pads.
2. Apply a small amount of solder to one of the pads (so there is a slight bulge visible).
3. Hold the component in place with a pair of tweezers while you heat the solder that you just applied to the pad with the soldering iron. That will hold the component in place while you apply solder to the other leads.
4. Lay a piece of fine-gauge solder wire along side the component leads on top of the pads. Bring the tip of the soldering iron into contact with the solder, the component lead, and the pad for just enough time to reflow the solder.
5. If necessary, apply more solder to the lead that you initially tacked down.

Once you have finished assembling your PCB, test it with a multimeter. Fix it if necessary.



BAM
1/8/2014

● ● ● ● ● 5V

● ● ● 2.5V

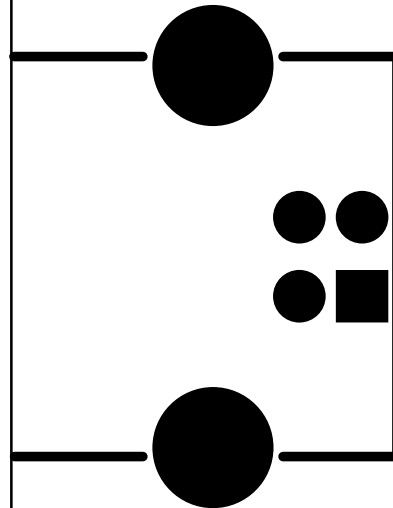

2.00 kΩ



Note that the LED has a two green marks on one side. They should be on the right.



MCP1525T



10 μF

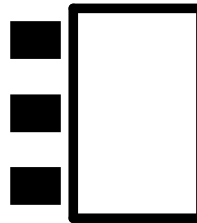

NCP1117ST50T3G

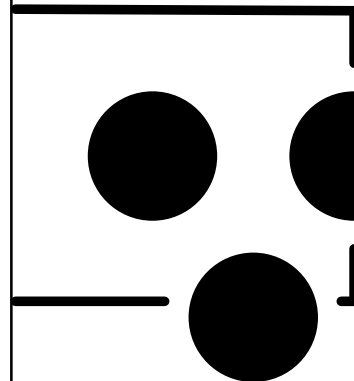

10 μF



● ● ● 2.5V

● ● ● ● ● 0V

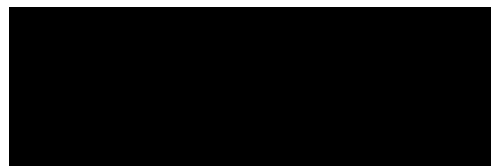

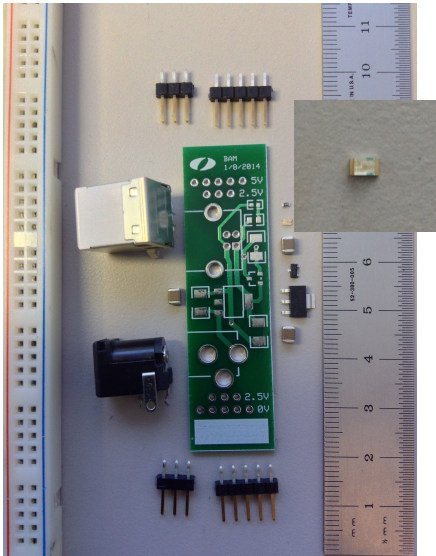

All of the components around a PCB. Note the green marks on the LED.

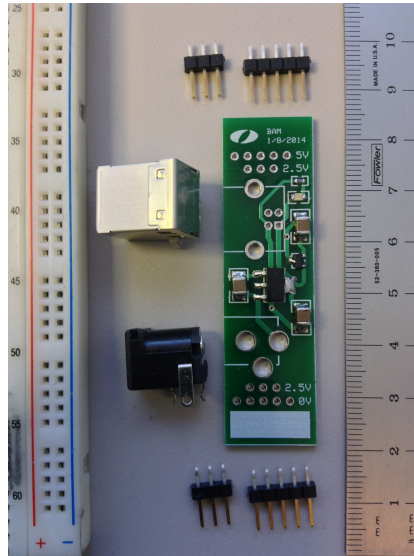

First, solder all of the surface-mount components.

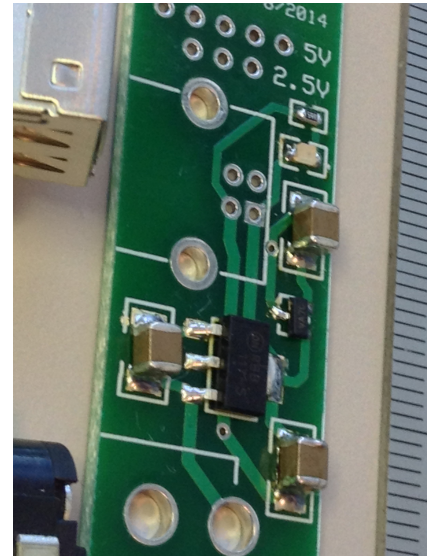

Close up showing solder fillets from the left side.

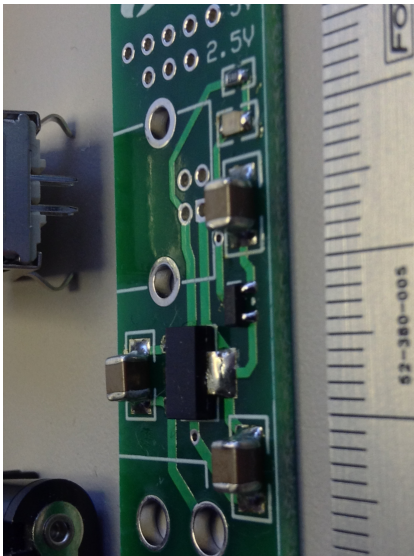

Close up showing solder fillets from the right side.

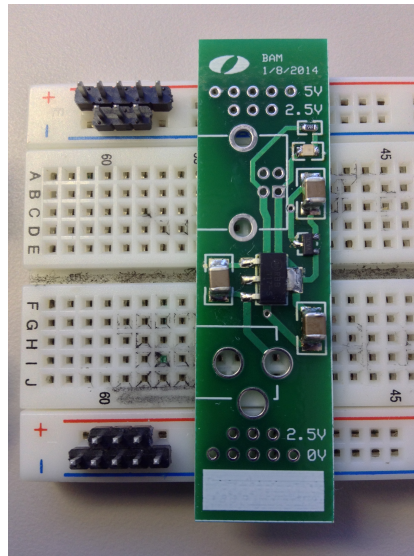

Use an old solderless breadboard as a jig for holding the header pins.

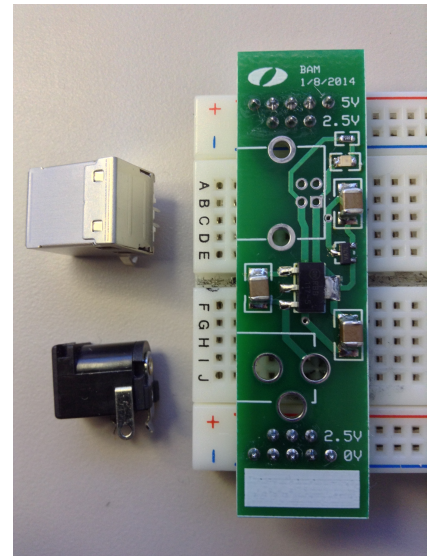

Solder the header pins on the top side of the board, as shown.

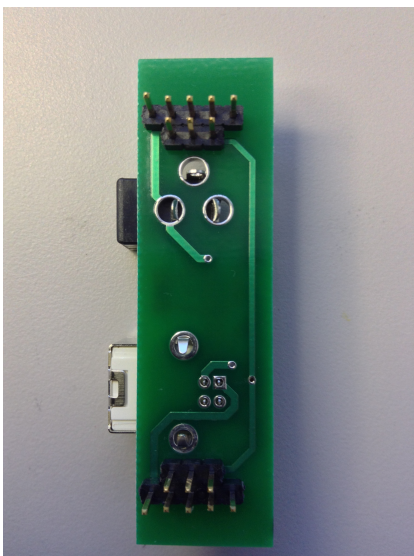

Insert the USB and the barrel jack connectors. Flip the PCB over.

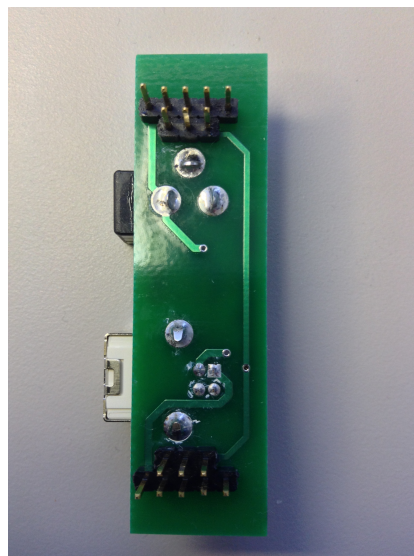

Solder the USB and the barrel jack connectors from the underside.

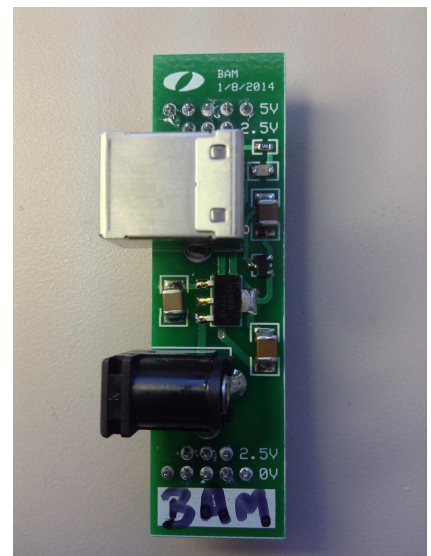

Remove flux residue with alcohol, initial the board, and test it out.

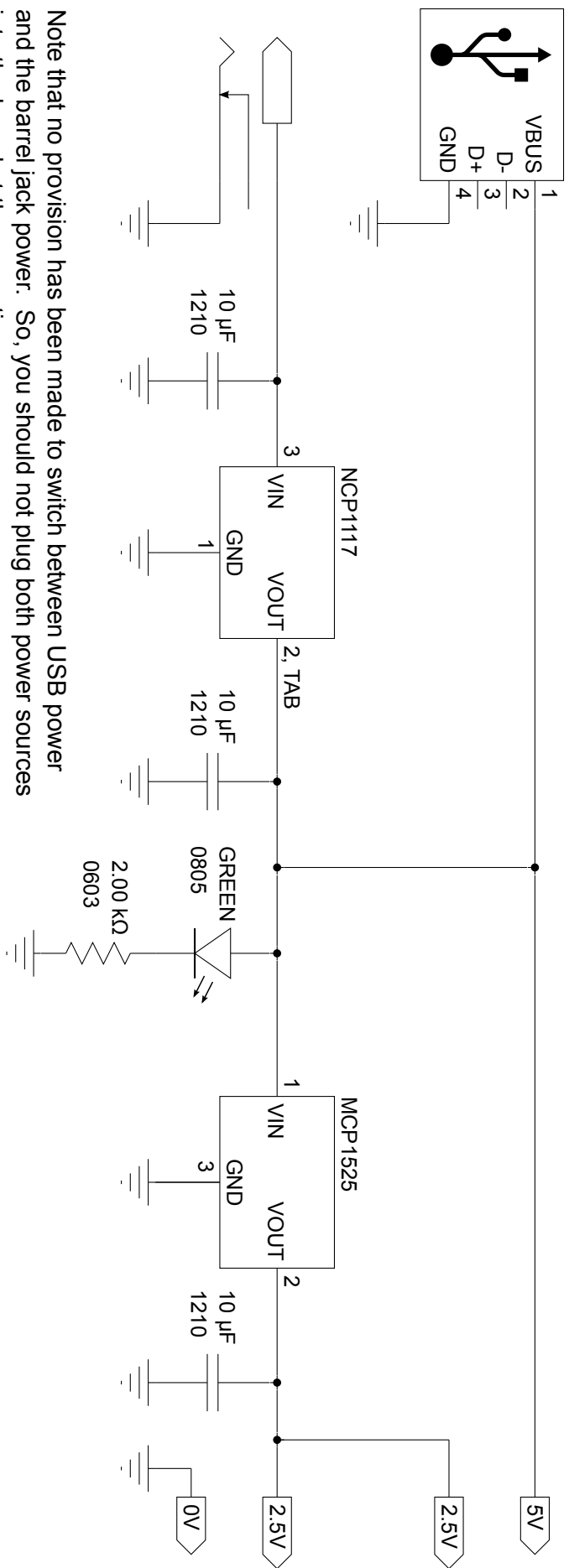

Note that no provision has been made to switch between USB power and the barrel jack power. So, you should not plug both power sources into the board at the same time.