

Lab 8: Pulse measurement with light – (pseudo) Oximeter

Goal: Design an oximeter using a photodiode, filters and op-amps.



Your deliverables for this lab are:

- 1) Your final circuit schematic, i.e. a copy of Figure 1 but with your final values selected. You can hand sketch it. Include the resistor values on the schematic. Include the actual cutoff frequencies and amplifier gains. You can sketch the circuit, but it should be neat enough that someone else in the class could build the circuit off your drawing.
- 2) Provide a short explanation/calculation that shows how you selected resistor/capacitor values.
- 3) A picture of your final circuit. It should be neat with clipped straight wires, low profile resistors, clean lines, and no loopy stuff.
- 4) One nice clean scope trace of your pulse with this circuit.

Overview

A pulse oximeter is common piece of hospital equipment that is used to measure a patient's pulse and the oxygen content of their blood. The device works non-invasively by shining and detecting light through the finger. You will design and build the first part of this device, the **pulse detector**.

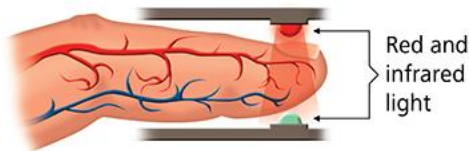

Source: <http://www.nonin.com/What-is-Pulse-Oximetry>

These are the **functional requirements** of your **pulse detector**:

- Capture variation in light through your finger in the 1 Hz to 10 Hz range;
- Amplify the raw signal ~ 100 times.

Here's a block circuit diagram:



Take a minute to imagine the relevant circuit component for blue components from previous labs. Can you imagine designing the R's or C's for each?

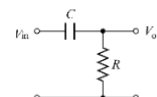
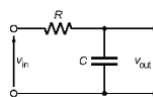
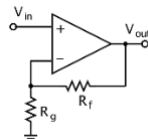

Light detector

A photodiode is a device which turns photons (light) into current. It's a transducer (light → current).



The I generated by the photodiode we will use is quite small--on the order of $1 \mu\text{A}$ (micro-amp) for ordinary room lighting. We must turn this small I into a voltage, V , that we can measure reliably.

For the light detector, build the circuit below, right, using the LMC6484 op-amp chip.

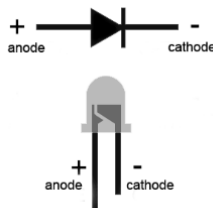

<https://www.allaboutcircuits.com/tools/led-resistor-calculator/>

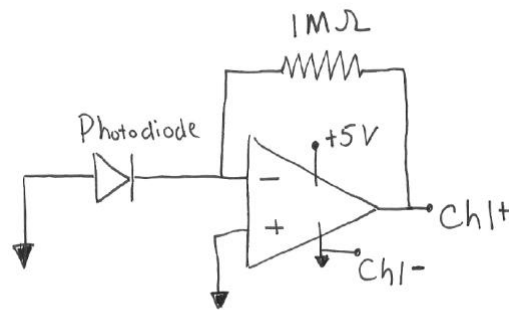

When the photodiode creates current from the light, that current cannot go into the op amp's input.



Why?

Where does the $I_{\text{photodiode}}$ go instead?

How is the voltage measured at Ch+1 related to $I_{\text{photodiode}}$?

Is your device working? If you monitor the voltage out of the light detection circuit, then you should see the signal change as you cast shadows on the photodiode. Wave your hand around the photodiode and see that the signal makes sense to you. If the photodiode is in the wrong orientation, then the circuit will not work (just turn it the other way!).

Now add a **10 nF capacitor in parallel with the 1 M resistor** to the circuit. You should notice a reduction in high frequency noise. The fluorescent room lights blink at a specific frequency – which many of you can hear – and you should see these fluctuations diminished a little bit by inserting the capacitor. We will analyze **why** the capacitor works in a later class, for now, just note what the capacitor does experimentally

Design & build

Previously, you measured your pulse by sensing the electrical activity of your heart. This week we will repeat this measurement, but we will sense your pulse by measuring the light intensity through your finger. Your blood changes color (slightly) based on levels of oxygenation, and thus the intensity of light that passes through your finger fluctuates with your pulse.

Design and build your circuit using Figure 1. Please note that there is no single “right” answer. Anything close to the specified functional range should work just fine. You could try a few values for each unknown component and see how the circuit behaves and what you like best.



My op-amps supply $I_{max}=20\text{ mA}$.

What value of R should I not go below?

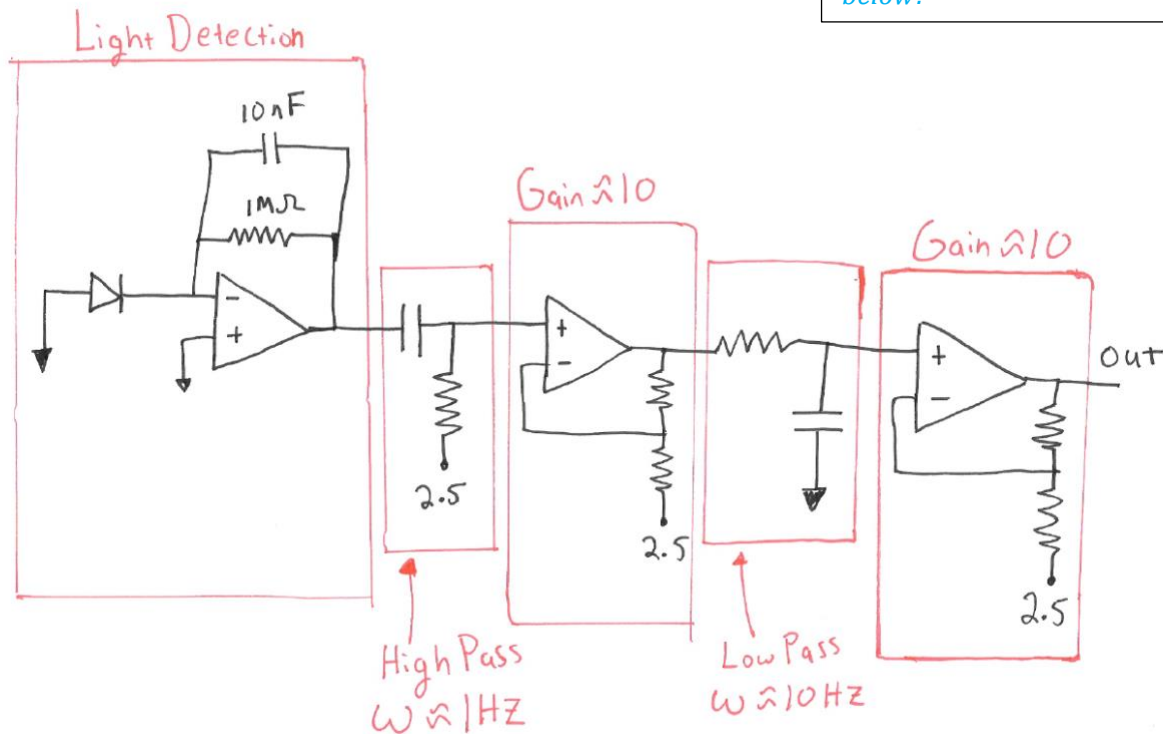

Figure 1: Circuit to measure the variation in light intensity through your finger.

Connecting to the Analog Device:



How does using +2.5V as a reference for the amplifiers change the output?

If using Ch1+ to measure the V_{out} where on the breadboard should Ch1- go?

Test

Once the circuit is built, *lightly* place your finger over the photodiode. Pressing hard will reduce the circulation to your finger. By holding still for a few seconds your pulse should emerge. Resting your hand on the table and trimming the length of the photodiode leads works well, otherwise your slight hand movements can obscure the effect. This circuit is sensitive to the absolute intensity of light and thus you need to hold still for a moment to let the high pass filter do its work.

Here is an example using Ch2+for V_{out} . The circuit uses the Figure 1 design with two amplifiers of Gain=11 each and filters that pass signals between 1 Hz and 10 Hz.



Are your individual circuit block elements working?



How could you use Wavegen as a signal source to test each circuit block?