

## Lab 9: Ballistocardiograph

Goal: Build and test a ballistocardiograph from strain gauges, op-amps and second-order filters.



**Deliverables:** A short lab report that includes...

1. The Bode plots of the filter stages as requested below (look for **red text** and this icon:  ).  
*You do not need to have an analysis of the band-pass filters, however, you should be able to identify the important frequencies given by the RC values of the circuit.*
2. A good clean BCG trace, similar to what is shown in Figure 1.
3. A picture of your beautiful circuit.

### Measuring reaction forces of your heartbeat

When your heart beats, it essentially throws a volume of blood upwards, out of your heart. Each beat produces a slight recoil force that can be measured on an ordinary bathroom scale.

The principle is the same as if you stand on a scale and flap your arms, the weight the scale reads will go up and down.

Such an instrument is known as a ballistocardiograph (BCG). Since the measurement is so sensitive, we can do a simultaneous EKG which will help us identify and correlate the two signals, shown below in Figure 1.

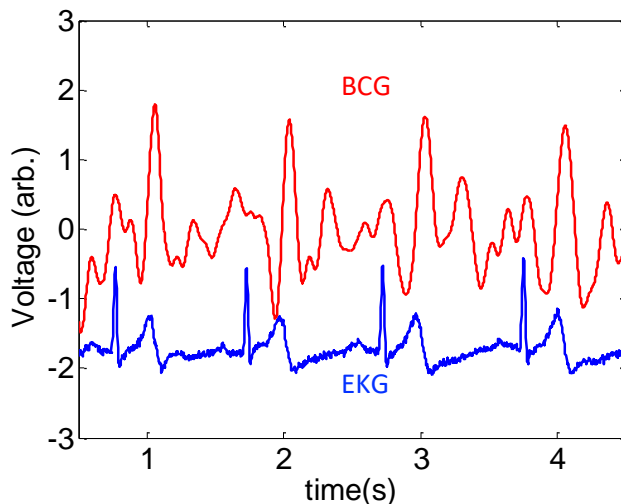

**Figure 1:** Comparison of EKG (blue) and BCG (red) signal. Note the regular correlation between the second hump of the EKG signal and the impulse from the BCG.

We have only 6 scales for 100 students. Please use the following precautions:



1. Handle scale and their wires with care;
2. Ensure your circuit works prior to testing with a scale;
3. Leave all scales in the ISIM lab (they can be used in adjacent rooms for testing).



## The circuit design

The functional requirements of this circuit design were:

1. Amplify the difference in the scale strain gauge outputs by 101;
2. Remove the DC offset voltage due to your mass from the signal;
3. Strongly filter out noise outside of the  $\sim 1$  Hz heart signal to isolate your pulse;
4. Remove the frequency oscillations due to your balance which is never stationary.

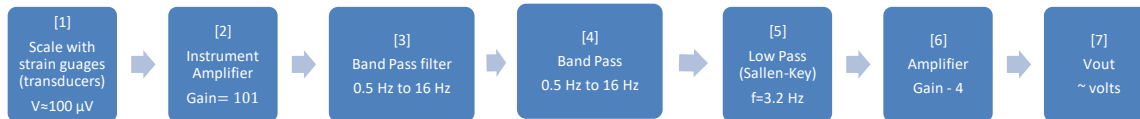
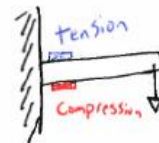
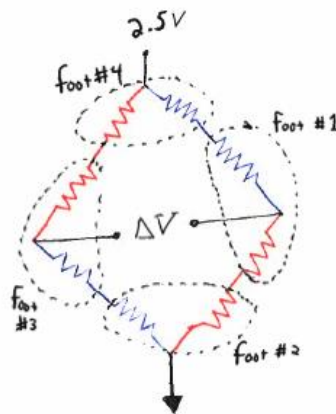
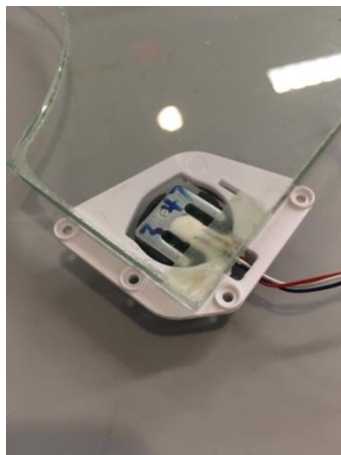

Figure 2: Block diagram of your circuit.

## Principles of operation of the scale

The basic principle of the bathroom scale is the use of the strain gauge to measure the weight – just as you did earlier in the semester. The first step is to use the instrumentation amplifier, more or less the same as the strain gauge lab.

The main difference from the strain gauge lab is that the resistors for the Wheatstone bridge are the strain gauges located in the each of the four legs of the bathroom scale. As schematically indicated below, there is a gauge mounted on the top (blue) of the cantilever and one on the bottom (red).



Side view of cantilever in the scale's foot. Strain gauges are mounted on **top** and **bottom**.

When you stand on the scale, the cantilevers in the feet will be bent downward. The, **top** will be in tension ( $R\uparrow$ ), **bottom** will be in compression ( $R\downarrow$ ).

Since the strain gauges are more precisely manufactured than standard resistors, there is no need to balance the bridge with a potentiometer.

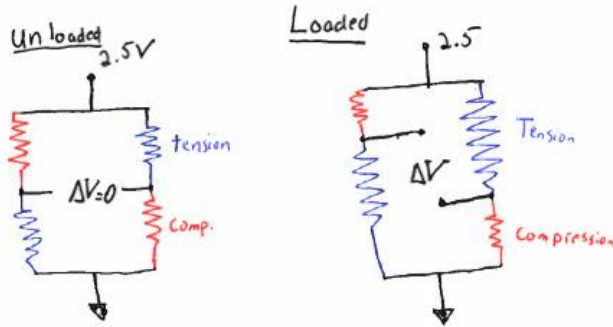

What happens to ΔV?

Note: The strain gauge is powered with the 2.5 V reference. This choice was made as the 2.5 volt reference is much more stable than the 5V from your USB. The 2.5 volt reference is not able to supply much current, however in this case the resistance of the strain gauges limits the current to less than 1 mA, which is acceptable for the voltage reference

**Building the circuit**

The end of the lab contains three circuit diagrams stages that go with the block diagram above, Figures 3, 4 and 5. You may recognize parts of the circuit as functional elements that you've seen before.

For example, here is a low pass filter with a cut-off frequency of:

$$0.8MHz = \frac{1}{2\pi(2 \times 10^3 \Omega) \cdot 1 \times 10^{-9} F}$$

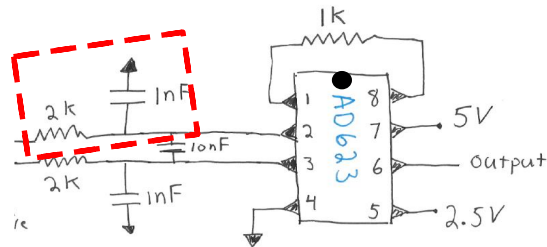

See if you can draw a boundary around sections of the circuits that are associated with block numbers [#] in Figure 2.

The AD623 and LMC6484 chips schematics are shown below for reference.

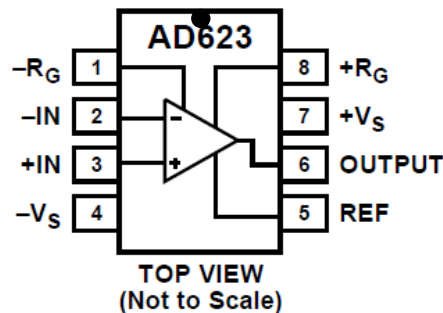
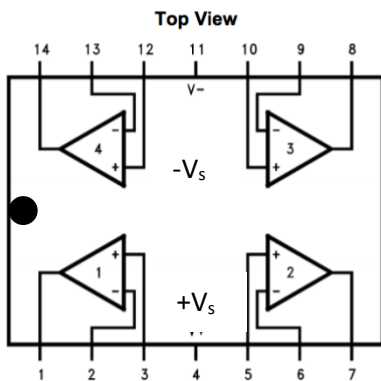

00778-001

You should build each block in turn and then test after each new additional block.

Each block from Figure 2 is essentially buffered by an op-amp, the blocks do not interact with each other and can be built, tested, and analyzed in isolation.



*An op-amp that is downstream of another does not draw current.  
How do we know?*

### Build stage 1 (Figure 3)

In the first stage, Figure 3, you will note that there are some resistors and capacitors at the front end of the circuit. This arrangement is suggested by the manufacturer of the instrumentation amplifier chip to reduce RF interference. Since there is a fair amount of electrical noise in our room the overall performance seems much improved with this circuit up front.

When you've completed the build of Figure 3, you may want to test the circuit quickly using one of the scales. The output signal at this point will be a voltage proportional to the weight on the scale. If you measure the output of the instrumentation amplifier and stand on the scale, you should see a voltage change. The output voltage when there is no load should be close to zero but not exactly (maybe a few hundred mV). This offset voltage has to do with some slight imbalance of the bridge resistors. When you stand on the scale, the voltage may go positive or negative depending on which wire goes into the positive input of the instrumentation amplifier – it doesn't matter. At this point if you see changes when you load the scale of 10-50 mV, you are probably on the right track.

### Build stage 2 (Figure 4)

The next stage, Figure 4, consists of two bandpass filters with cutoff frequencies of 0.5 and 16 Hz.

A single band-pass filter will attenuate (i.e., make smaller) signals outside of the frequency band by a factor of 10 by each factor of 10 beyond the cutoff frequency.



*By cascading the bandpass filters, what is the factor of reduction in Amplitude of the signal for each factor of 10 beyond the cutoff frequency?*

This configuration is a second-order roll off filter.

Each of these two filters also has a gain of 33 built into it. Test each filter in isolation of the scale using the network analyzer on the Analog Discovery. **Include one of the Bode plots of the single filter in your lab report**, but test both individually.



Note that the filters are referenced to 2.5 volts and have high gain, so your input signal for the network analyzer should be offset to 2.5 V and of something like 50mV. Note that we haven't quite yet discussed

in class how to analyze the circuit in Figure 4. For now, characterize them experimentally and we will analyze them in coming weeks.

At this stage, you could also check the circuit with the scale attached. If you hook the scale up, you should see that the circuit is very sensitive to light tapping on the scale. If you monitor the output of the second op-amp in Figure 4, it should be sensitive to light tapping around once per second. You don't need to include this result in your lab report – it's just for you to test as you go.

### **Build stage 3 (Figure 5)**

Now build the final stage. This consists of a second order low-pass filter with a cutoff frequency of 3.2 Hz. The topology of the circuit shown with op-amp C in Figure 5 is called the Sallen-Key topology. We have not discussed this circuit in class, but it has a second order roll off above 3.2 Hz. We will analyze this circuit more next week.

Test the filter in isolation with the network analyzer and include the **Bode plot in your lab report.** 

Finally, with op-amp D we have a gain of 4. For your setup you may need/want to adjust the amplification factor. You may find you get a satisfactory signal out of op-amp C.

Once you have the entire circuit built, you can try to test with one of the scales. The scale should be very sensitive to just a light tap with your finger. If the signal does not respond to a light tap, then it will not work when you stand on it.

## **Troubleshooting tips**

Finding your heart rate is challenging, so you have to do this with care. Some tips are

- Keep the scale on a hard surface.
- Hold very still. It is hard to get more than 4 or 5 clean beats in a row before you wobble and swamp the signal.
- If you find the electrical noise in the lab is too much, try the hallway with your laptop on battery, though you will need to place the scale on a hard surface.
- Place your fingers on your wrist to find your pulse, you can often see the peaks of the BCG signal correlating with your pulse.

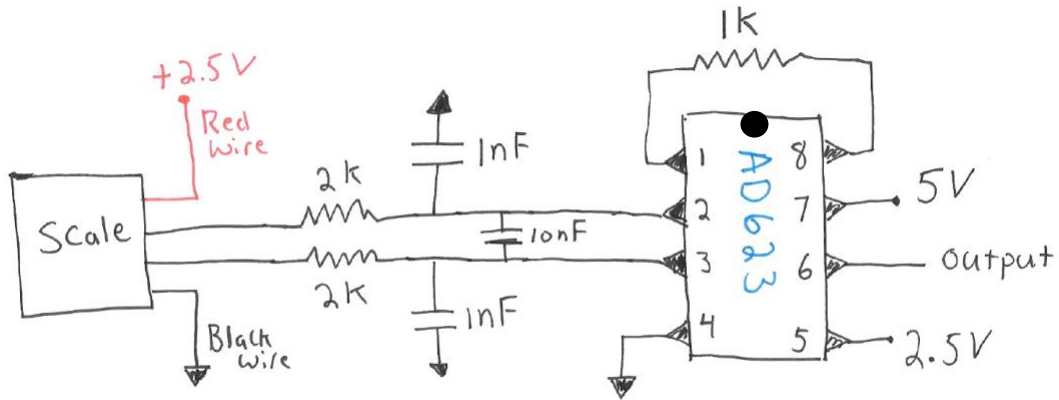

Figure 3: First stage of the circuit. Instrumentation amplifier interfacing with the strain gauges in the scale. The strain gauges inside the scale form a Wheatstone bridge.

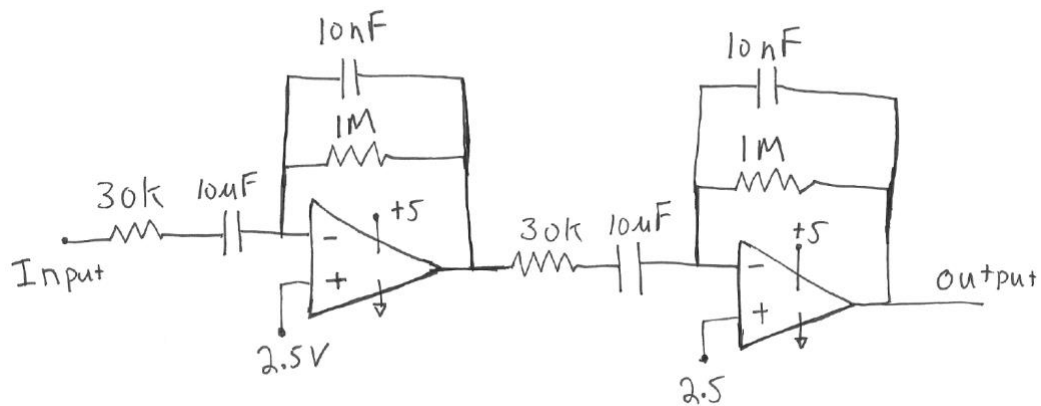

Figure 4: Two bandpass filters with cutoff frequencies of 0.5 and 16 Hz and a gain of 33.

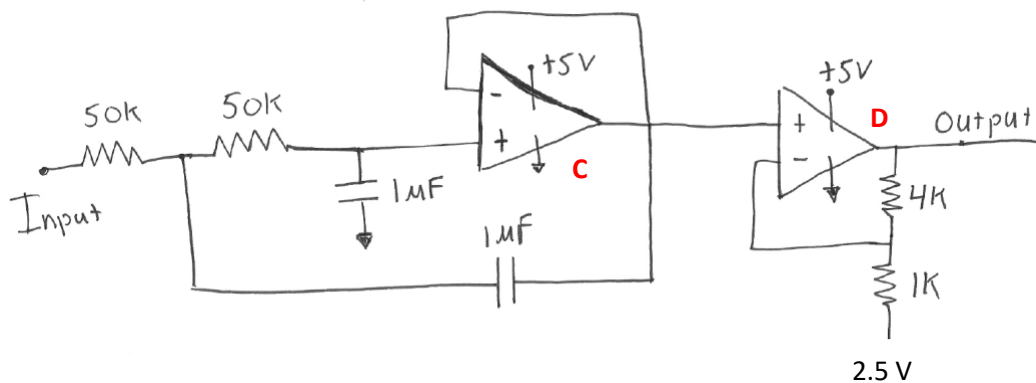

Figure 5: Sallen-Key second order low-pass filter with a cutoff frequency of 3.2 Hz. The amplifier following this filter has a gain of 4 set here, but you may find you want to adjust this value.