



Lab 10: Ultrasonic range finding

Goal: Design, build and test an ultrasonic range finder.

 **Deliverables:** A concise lab report that includes...

- 1) A schematic of your receiver circuit.
- 2) A measured Bode plot for your complete receiver circuit. You DO NOT need to compare to the analytical solution this week, but if you want to try and compare to the prediction, be our guest!
- 3) A picture of your final, breadboarded circuit. It should be compact and pretty.
- 4) Representative data from a single blip with the transmitted and received signal on a single plot. Denote on the graph the time where the echo would be expected to be returned from the known distance to the wall.
- 5) A plot of “measured distance from your ultrasonic range finder “vs. the known distance. Plot all your data as points on a scatter plot.
 - a. Comment on how well your range finder works (Is it linear? does it give the correct result?).
 - b. Comment on to what accuracy you would trust your range finder (this is an estimate, we have not discussed statistically how to make these judgments in a more formal way!).

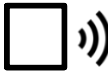
Above there are requests for 5 figures; Keep your lab report focused on these 5 figures.

**AC428 ONLY**

We need you to leave the ultrasonic range finding boards in our ISIM classroom. We only have enough for each section. You're welcome to return during non-class hours and use them.

Overview

In this lab you will design and build an ultrasonic range finder capable of measuring distance by emitting a brief burst of ultrasound and measuring the time it takes for an echo to return. The transmitter will send out a short burst pulse at the transducer’s operating frequency of 40 kHz. The receiver will find the reflected acoustic signal, then filter and amplify this signal. We use the same type of transducer to transmit and receive the signal. You will build two circuit systems, the transmitter and receiver. We will provide the transmit circuit; You will need to design the receiver circuit.

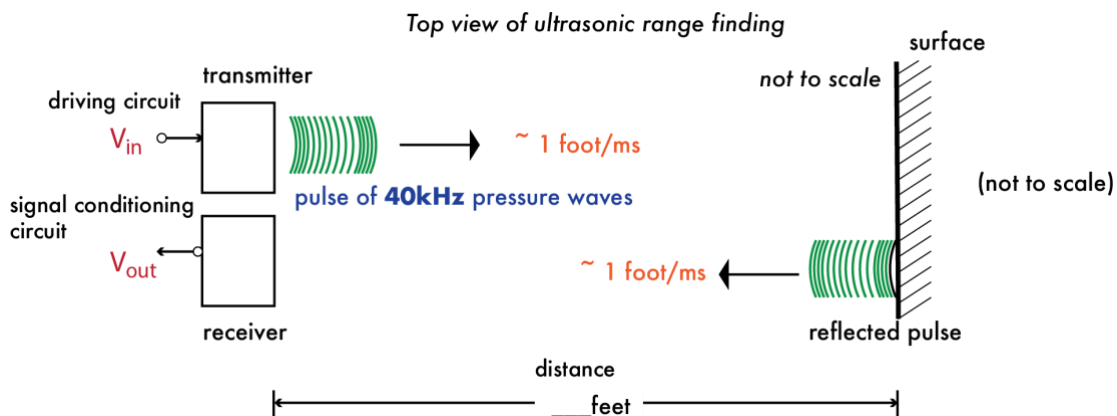

Figure 1. Concept of ultrasonic range finding. You can compute the distance from the receiver to the reflected surface from the time between the emitted and received pulse.

The block diagram for an ultrasonic range system may look something like this:



As usual, the measured electrical signal will contain a mix of frequencies.

For this ultrasonic range finder, which exact frequency should the receiver circuit isolate?



Transmitter

The ultrasonic transmitter is activated by $V_{in}(t)$. This driving signal, $V_{in}(t)$, is a pulse of 40 kHz, 3.3V square waves. The pulse should run for about 1 ms and then pause for tens of ms before repeating. This square waves in the pulse are converted to mechanical vibrations of the same frequency by the piezoelectric ceramic material. The horn (Figure 2, lower right) transfers these vibrations to the air.

To create the driving signal, the Analog Discovery will output 40 kHz and 20 Hz signals into an AND logic gate; this gate will output a high voltage (5 V) when input 1 AND input 2 are high.

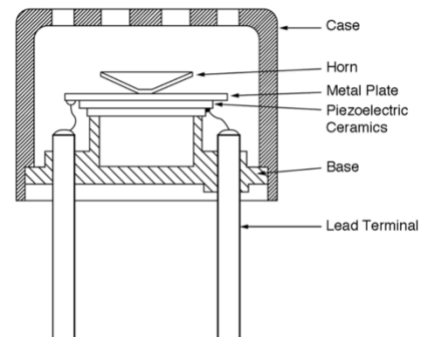
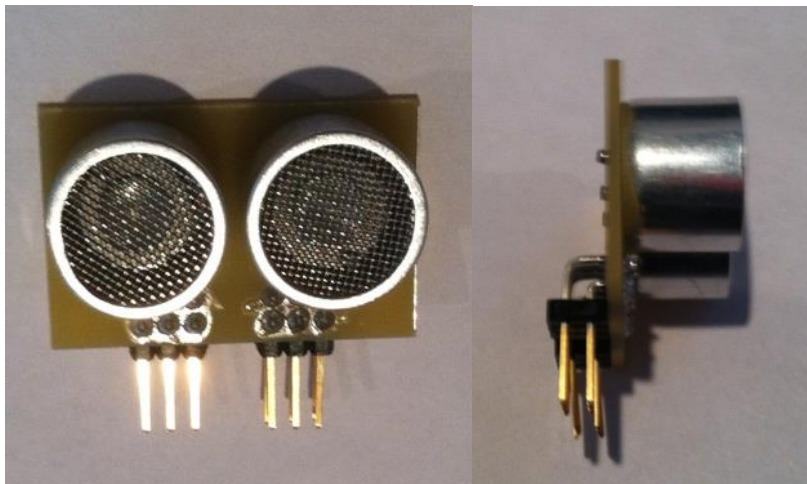
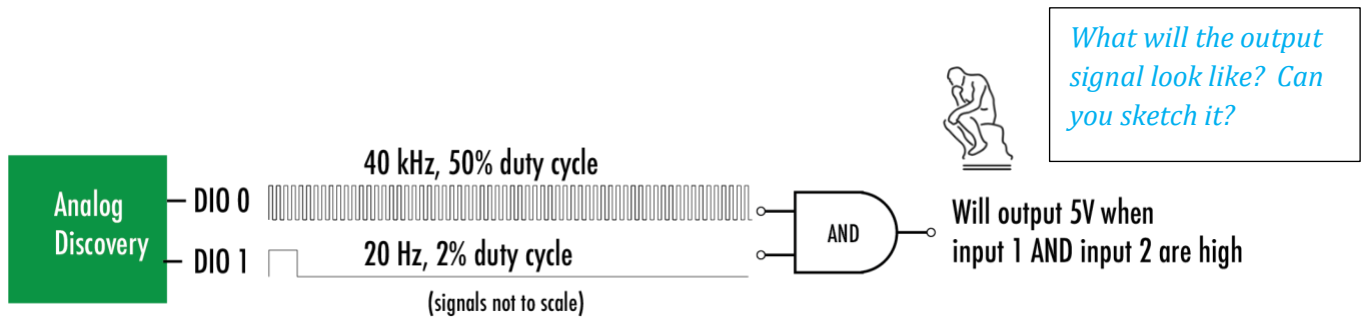
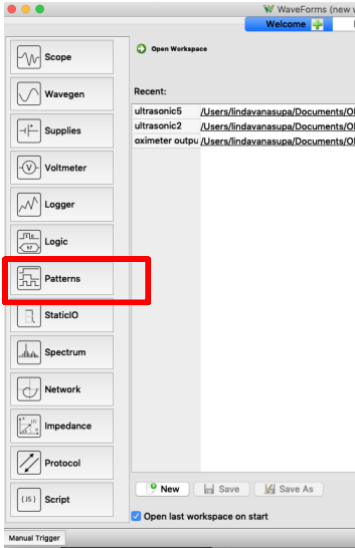
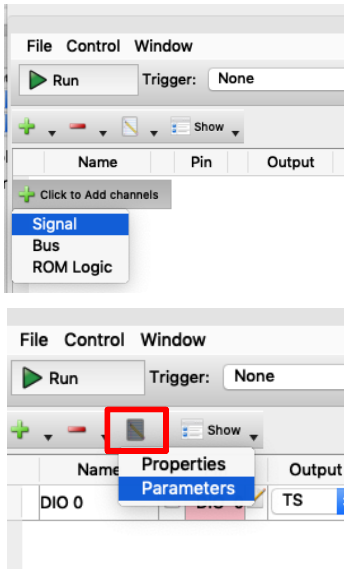

Figure 1: The transducer board for the ultrasound experiment. The transmitter and receiver are the same. The gap in the pins should straddle the middle break of your breadboard. The transducers have no preferred electrical orientation. Connect them to the end of the breadboard as shown below. Schematic by M. Chevrier and S. Yadav, <http://www.ti.com/lit/ug/tiduai8a/tiduai8a.pdf>

Add a **Patterns** function on the Analog Discovery.



To create the inputs to the AND gate,



- Click “+Add” and then “Signal”.
- Select DIO 0 (Digital Input/Output Channel 0)
- Set the type to “clock” and the output to PP.
- Click on the “edit” icon next to the “+” and “-“.
- Select “Parameters” and change the frequency to 40 kHz
- Set the cycle to 50%.
- “+Add” and then “Signal”.
- Select DIO 1 (Digital Input/Output Channel 1)
- Set the type to “clock” and the output to PP.
- Click on the “edit” icon, select “Parameters”
- Set frequency to 20 Hz (NOT kHz!) and duty cycle to 2 %.

You will have two signals. The pin colors correspond to the color of the associated digital output pin.

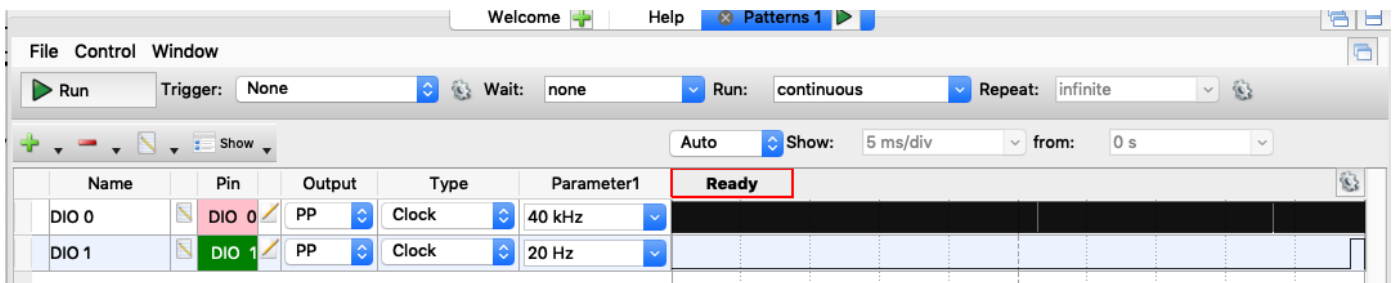

► **Run** and verify that the output signals on DOI 0 and 1 are as expected.

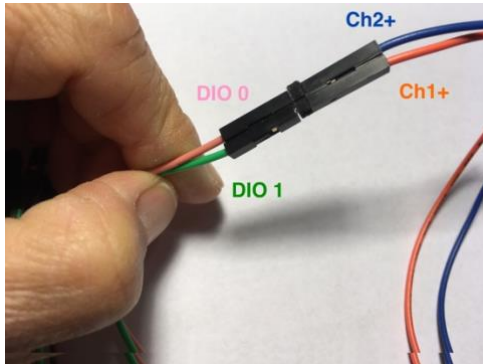

Your signal will be cleaner if you also connect Ch1- and Ch2- to ground.

Build the transmitter circuit



The output of the chip should be connected to the ultrasound transducer **before** initiating the driving signal to the logic chip. For some reason that is not fully understood, if you measure the output of the SN74ATC08 not attached to anything, you may get something odd.

Install a [Texas Instruments SN74ATC08](https://www.ti.com/product/SN74ATC08) chip on your breadboard. We'll be using one of the AND gates on this chip.

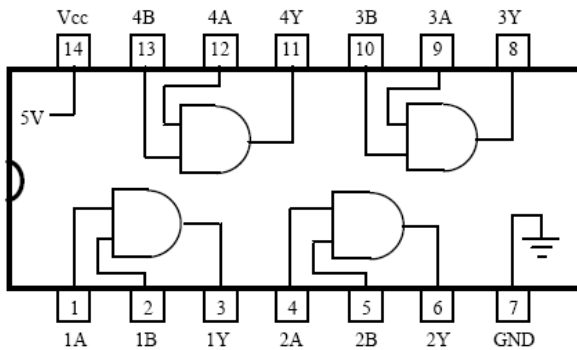

By Pravymon - Own work, CC BY-SA 4.0, <https://commons.wikimedia.org/w/index.php?curid=52623335>

Figure 3. Pin diagram for the SN74ATC08.

Wire the chip for power using Figure 3 or the specification sheet. Also, connect the Analog Discovery to one of the AND gates on the SN74ATC08.



Does it matter which AND gate on the SN74A TC08 that you use?

Plug the transmitter/receiver board into your breadboard – on the opposite end from the power connector such that the pins connected to the transducers straddle the middle break in your breadboard. Face the transducers outward from your breadboard. The transducers are the same so you may select whatever is convenient to be the transmitter.

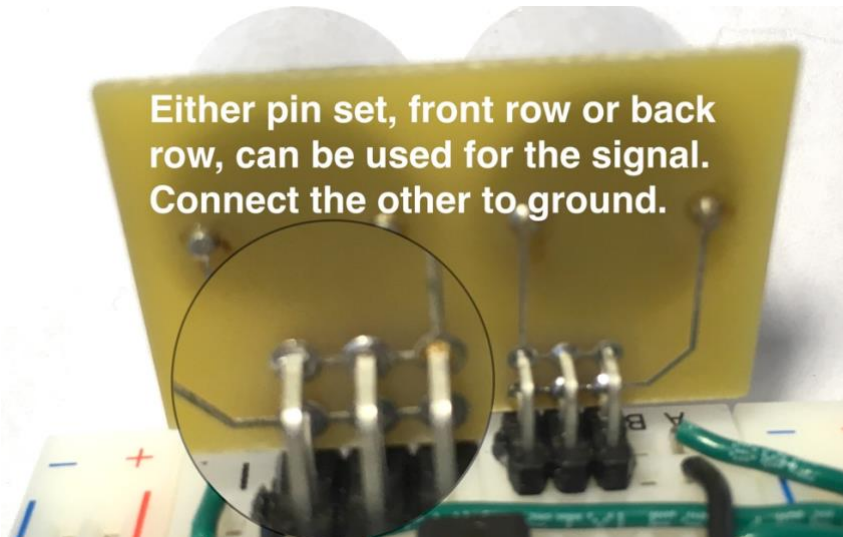
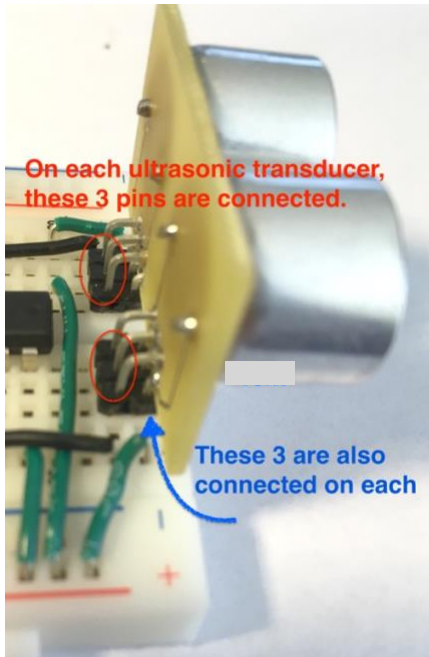

Note: Each transducer has 2 sets of three pins. We are using 3 pin for stability; as shown, they are electrically connected.



The output of the AND gate is the transmitter driving signal, $V_{in}(t)$.
For your design, which pin of the **SN74ATC08** is the output of the AND gate?

Wire the output of the AND gate to the input of the transmitter. Wire the Analog Discovery Ch1+ so that you will be able to monitor this transmitter driving signal.

Test the transmitter driving signal

You should see a 40 kHz square wave which is on for about 1 ms.

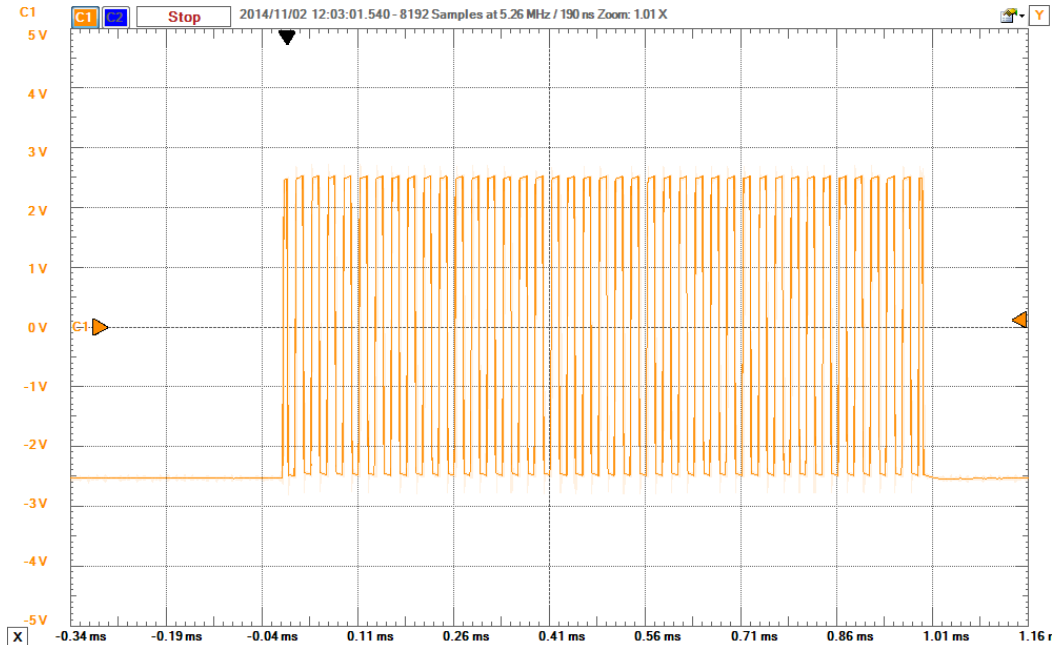

Figure 4: Example of the measured transmit signal. The 1 ms pulse has a 40 kHz carrier wave.

Receiver: Design and build the signal conditioning circuit

Like the transmitter, one of the transducer’s electrodes will be connected to ground. The other will be the signal that you send to your receiving, signal conditioning circuit. (At the end of this document you’ll find some tips for design and testing.)

Your receiving, filter and amplifier circuit should have the following (approximate) properties:

- The circuit should have a band-pass filter centered on 40 kHz
- The filter should have at least a second order roll-off above and below 40 kHz. By second order, we mean that for every factor of 10 in frequency above and below the 40 kHz pass-band, the output should be designed to fall by a factor of 100.
- The circuit should amplify signals at 40 kHz by a factor of about 1000 (60 dB).
- Your circuit elements should progressively amplify the signal – don’t try to get the whole factor of 1000 gain in one shot.
- The output of the circuit should be centered at 2.5V. Reference all your high pass filters and op-amp circuits to 2.5V.



There are many effective designs. For example, we’ve covered an op-amp design that is a band-pass and amplifier all in one—very effective and efficient.

If you choose to add separate stages of filtering and amplifying, amplification should come AFTER a high-pass filter. Why?

We will have analyzed a circuit in the Problem Set: Analyzing Complex Impedance that will work quite nicely, so you may want to start by looking at your notes from class (or section 7.1 in the book). The circuit shown in class can amplify and band-pass.



You may be tempted to use the Sallen-Key topology. We would recommend AVOIDING this Sallen-Key circuit, as there can be some subtle instability issues.

Once you have your circuit designed and built, you should test it with the Network Analyzer.

- Temporarily disconnect the ultrasonic transducer acting as the receiver.
- Connect Ch1+ and W1 to the input of your circuit.
- Ch2+ should be connected to the receiver circuit output.
- Ensure that the Analog Discovery and your board are grounded; Ch1- and Ch2- will be at 2.5V.
- Create a Bode plot by setting the output to be offset by 2.5 V and the amplitude to be 10 mV. Note that for a 10 mV signal and a gain of 1000, the circuit will saturate since the op-amps can't go above 5 volts. The Bode plot will saturate when 10 mV is amplified by a factor of 250 or about 50 dB.



Depending on your circuit, you may find that the measured Bode plot deviates from what is predicted at higher frequencies. If you have a lot of gain in a single stage of the circuit, the deviation is likely due to the speed of the op-amp. We will discuss the op-amp dynamics next week in class. For now, if your measured Bode plot is not centered at the design frequency, you can simply adjust the resistor values a bit to push you into the proper frequency range. You will need to save a final Bode plot for your receiver circuit.

Range Experiment:

Aim your transducer at a wall. Sound travels about 1 foot per millisecond, so you should see an echo from the wall that should correspond to the distance the signal traveled (there and back). In the classroom, the floor tiles are conveniently 1 foot square. You can place your setup and laptop on a rolling cart. Walk in 1 foot increments starting from 2 feet, to about as far as you can go and still get a reasonable reflection (should have no problem getting 10-20 ft). Sample data for one ping is shown in Figure 5.

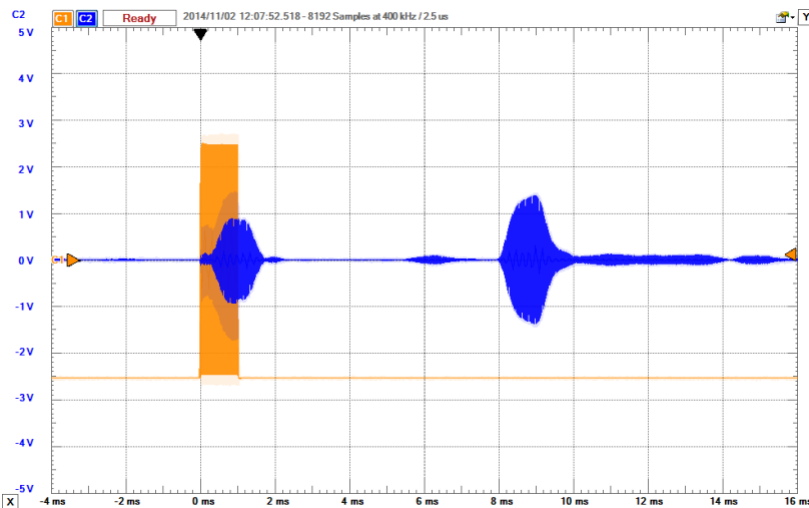

Figure 5: Sample data. The orange is the transmit signal and the blue is the received. In this case there is about 8 ms between transmitted and received signal, indicating the pulse traveled about 9 ft, or the wall is 4.5 feet away.



You might need to conduct your experiment in the hallway with a tape measure – if too many people are in the lab running their transmitters at the same time! **Repeat this for 5 distances.** It is not that important what the exact distances are, but that you know them. *Note: In our classroom, the floor tiles are 1 square foot.* **Plot all your data as known distance versus distance inferred from your circuit measurement.**

Tips and requests before building

1. Sketch out the circuit that you want to build before going to the breadboard. We can help you debug your experiment if we can see the circuit that you've designed and built.
2. Use Wavegen to test blocks of your design, but remember that the op amp amplifies the difference between the inputs (labeled – and +). For example, let's say you had a block within your circuit that looked like this:

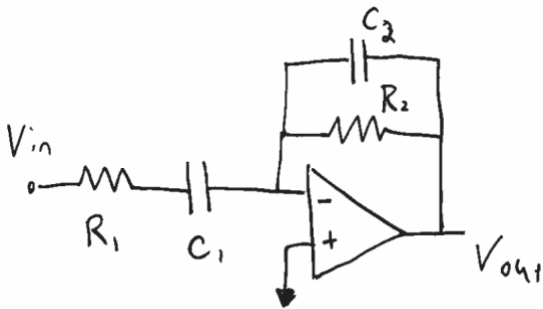

You may want to know what the cut-off frequencies are for this block.

You may want to know whether this block was behaving as a first or second-order roll-off filter.

A Bode plot of this would tell you everything you need to know about how it will treat V_{in} .

When setting up the Bode plot, these are the questions you'll need to ask yourself:



Choosing V_{in} : *The op-amp $V_{out, max}$ is it's $+V_{source}$. V_{in} will be amplified. Therefore, what is $V_{in, max}$?*

Choosing offset for V_{in} : *Because this block is in negative feedback, $V_{+}=V_{-}$. Therefore, does V_{in} need to be offset relative to V_{+} ?*

Choosing start and stop frequencies: *What are my frequencies of interest for this application? $f < 1\text{Hz}$ will take a long time to measure.*

Connecting Analog Discovery to V_{in} : *The W1 pin will provide my frequency variation. Use Ch1+ to monitor this input.*

Connecting Analog Discovery to V_{out} : *The Ch2+ will provide monitor the response. Where should this be connected?*

Connecting Ch1- and Ch2-: *Ch1+ and Ch2+ measure relative to the reference voltage, V_{+} . Therefore, where should Ch1- and Ch2- be connected?*

Connecting Analog Discovery ground: *Your measurements rely on a shared electrical point of $V=0$. Make sure your computer, the Analog Discovery and your circuit are connected to ground ($V=0$).*

Disconnecting (or not) the rest of the circuit before the Bode run: *Your block performance will be affected if there is significant current being drawn, up- or down- stream of your test block. In your case, should you disconnect your test block from the circuit, up- and/or down- stream of the test block?*