

Lab 4: Using Capacitors to Measure Humidity

Goal: Build a circuit to sense and compute relative humidity by measuring capacitance.



Learning objectives

- Employ the concepts from the capacitor PSet to design a sensor circuit ;
- Use the specification sheet for a sensor to determine the frequency and voltage inputs for the sensor;
- Construct a transfer graph (ΔV to %RH) from the data on the specification sheet;
- Calibrate your sensor circuit.

Visual Summary

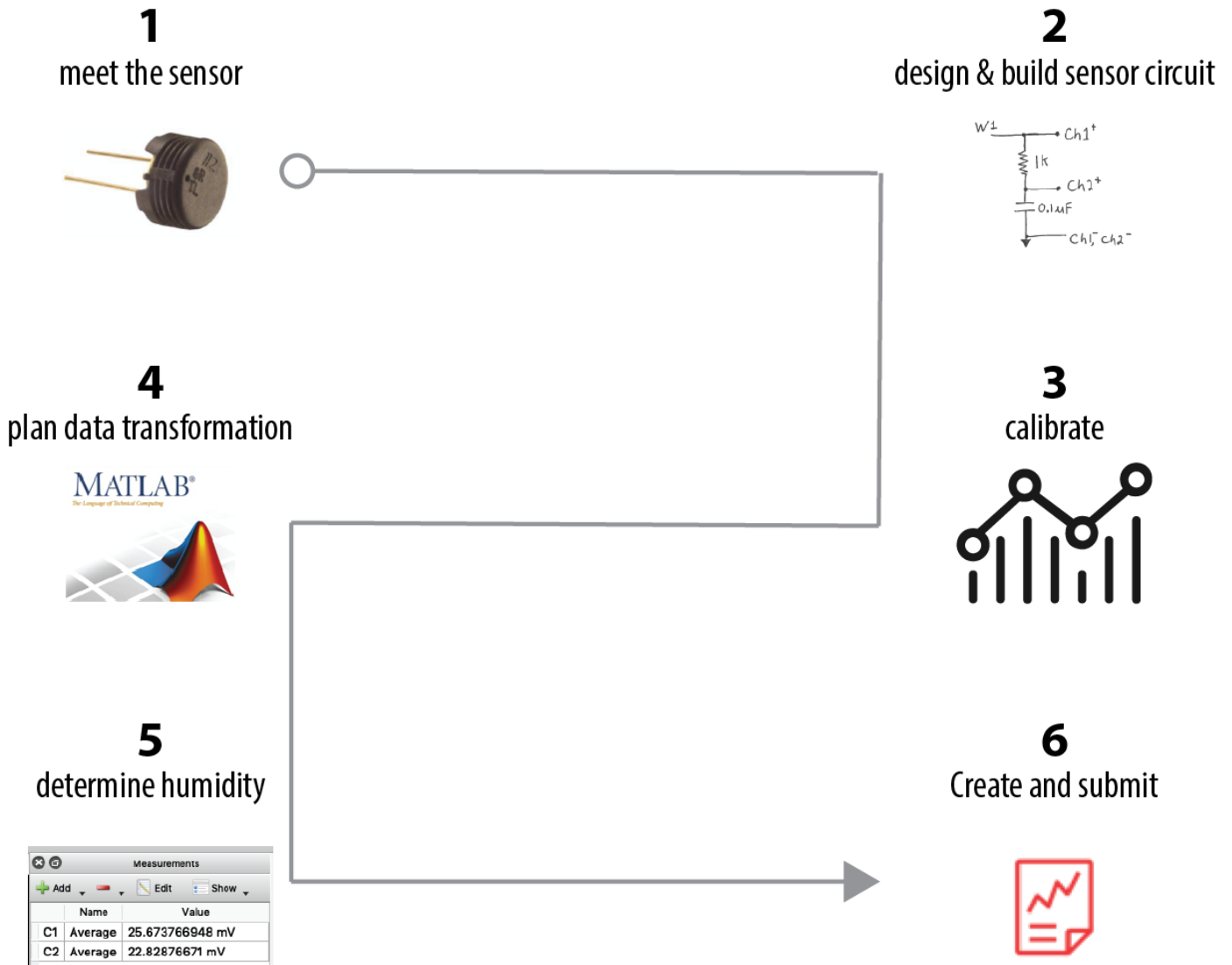

1. Meet the sensor

How can we sense humidity with a capacitor?

Now that you’ve been in Needham, Massachusetts for a few weeks, you’ve experienced humidity!

%RH *Relative humidity* is the percent of water vapor in the air *relative* to how much water vapor the air can hold before the water condenses—that is, before it rains or snows, depending on the temperature.

A capacitor is something that has the “capacity” to store charge. Often the charge is stored across parallel plates of metal, like so:

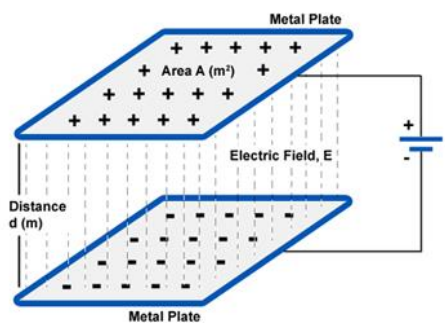

We normally refer to separated + and - charges as “electric potential differences” or “Voltage differences.”

$$\text{Capacitance} = \frac{\text{charge stored}}{\Delta V}$$

It turns out that we can increase the charge stored in a parallel-plate capacitor by placing a non-conducting material between the plates.

Source: <https://sites.google.com/site/nithinjoseph2066/electromagnetics/parallel-plate-capacitor>

In the case of this lab, for the humidity sensor, the material between the capacitor plates is a water-sensitive polymeric (i.e., plastic) material, likely cellulose ester.

It’s made from sugar molecules and looks like this in an electron microscope: The cellulose ester scaffolding is about 10,000 times smaller than the thickness of a human hair.

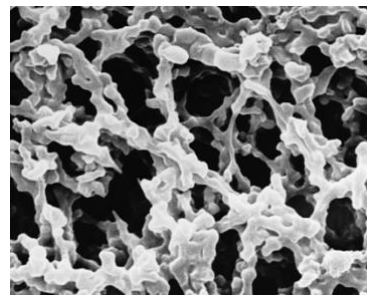

Source: <https://www.labsupply.co.nz/>

Water vapor from the air attaches to the surface of the cellulose ester fibers, enabling more charge to be stored in the capacitor:

Capacitance (C) ↑ with ↑ %RH

The %RH sensor

You are going to create a circuit that uses this [humidity sensor](#) (click link for specification sheet) as the *transducer*.



transducer: a device that converts one physical quantity to another

e.g. 

What is our transducer converting the humidity to?

The product specification sheet states how it will *perform* in a circuit and under what *circuit conditions*.

Roughly, what does the *transfer* or *reference* curve for your sensor look like?

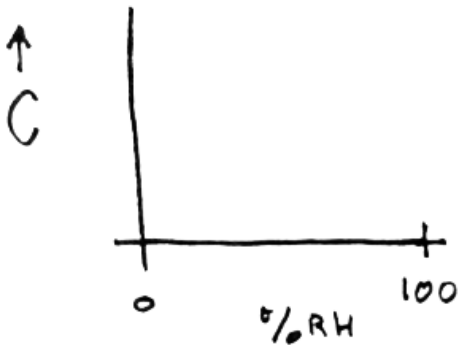

HS1101LF – Relative Humidity Sensor



ELECTRICAL CHARACTERISTICS OF HUMIDITY SENSOR

(T=25°C, measurement frequency @10kHz / 1V unless otherwise noted)

Characteristics	Symbol	Min	Typ	Max	Unit
Humidity Measuring Range	RH	1		99	%RH
Supply Voltage	Vs			10	V
Nominal capacitance @55%RH ⁽¹⁾	C	177	180	183	pF
Temperature coefficient	T _{cc}		-0.01		pF/C
Average Sensitivity from 33% to 75%RH	ΔC/%RH		0.31		pF/%RH
Leakage Current (Vcc=5V)	I			1	nA
Recovery time after 150 hours of condensation	t _r		10		s
Humidity Hysteresis				+/-1	%RH
Long term stability	T		+/-0.5		%RH/yr
Time Constant (at 63% of signal, still air) 33%RH to 80%RH	t _a		3	5	s
Deviation to typical response curve (10% RH to 90%RH)			+/-2		%RH

(1) Tighter specification available on request

TYPICAL PERFORMANCE CURVES

POLYNOMIAL RESPONSE OF HS1101LF

$$C \text{ (pF)} = C@55\% \cdot (3.903 \cdot 10^{-8} \cdot RH^2 - 8.294 \cdot 10^{-6} \cdot RH^2 + 2.188 \cdot 10^{-3} \cdot RH + 0.898)$$

TYPICAL RESPONSE LOOK-UP TABLE (POLYNOMIAL REFERENCE CURVE) @ 10KHZ / 1V

RH (%)	0	5	10	15	20	25	30	35	40	45	50
Cp (pF)	161.6	163.6	165.4	167.2	169.0	170.7	172.3	173.9	175.5	177.0	178.5
RH (%)	55	60	65	70	75	80	85	90	95	100	
Cp (pF)	180	181.4	182.9	184.3	185.7	187.2	188.6	190.1	191.6	193.1	

REVERSE POLYNOMIAL RESPONSE OF HS1101LF

$$RH (\%) = -3.4656 \cdot 10^{-3} \cdot X^3 + 1.0732 \cdot 10^{-4} \cdot X^2 - 1.0457 \cdot 10^{-4} \cdot X + 3.2459 \cdot 10^{-3}$$

With $X = C(\text{read}) / C@55\%RH$

MEASUREMENT FREQUENCY INFLUENCE

In this data sheet, all capacitance measurements are done @ 10 kHz / 1Volt. However, the sensor can operate without restriction from 5 kHz to 300 kHz.

2. Design and build the sensor circuit

Recall that throughout ISIM, we are simply taking a proxy measure using an instrument and transforming it through the wonders of math to our desired sensing goal.

Let's work backwards from our goal, using the image, right.

We desire to sense %RH (1). We know that the sensor will change capacitance with changes in %RH (2). We need a circuit that allows us to relate changes in capacitance to voltage (3).

You could *calibrate* the circuit (3) by simulating the circuit test conditions used to develop the REFERENCE CURVE (2).

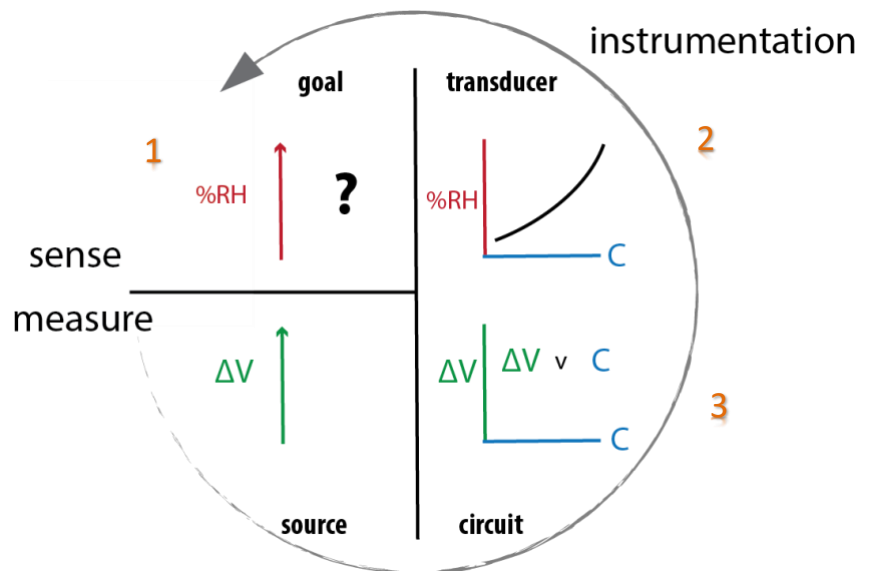

Figure 1. Concept of measuring to get sensing goal.

Both of the circuits below could work for the sensor, using a 10KΩ resistor. Choose one and build it using a 120 pF capacitor in the place of the sensor.

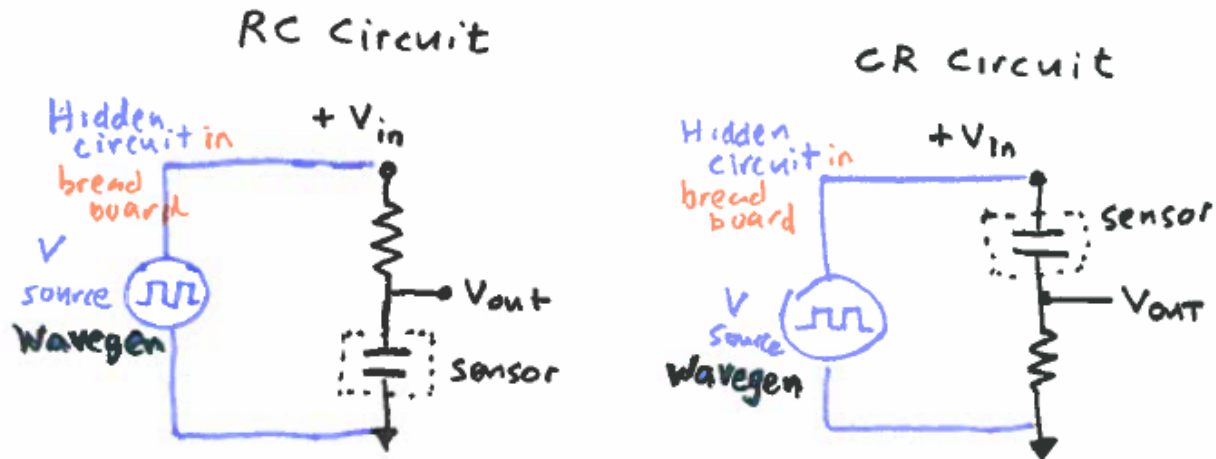

Figure 2. RC and CR circuits that will work with the %RH sensor.

3. Calibrate your circuit

If your sensor is powered and exposed to environments with a range of %RH, it would have different capacitances, as we can see from the TYPICAL RESPONSE LOOK-UP TABLE ([specification sheet](#), page 2).



If we want to duplicate the circuit conditions that produced the REFERENCE curve, what frequency (Hz) and voltage (Volts) should we input to the sensor? Hint: Check the specification sheet.

To create a calibration curve for your circuit, you can use capacitors of known values in the range of the transducer's response (100-220 pF) to simulate the sensor in differing %RH environments.

Connect the Analog Discovery and take the calibration data

There are several, equally-usable ways to connect to your sensor your circuit for the calibration. Connect your Analog Discovery so that it meets these functional requirements:

1. The AD, your computer and sensor circuit share a ground;
2. You can program Wavegen to input V_{in} as shown in Figure 2;
3. You can monitor the input V_{in} ;
4. You can measure the V_{out} as the calibrated signal.

 **Suggestion:** *Sketch your circuit and AD connections to include with your report.*



Where in your circuit will you connect Ch1- and Ch2-?

Set up Wavegen to power the sensor circuit

Set  , then ► Run

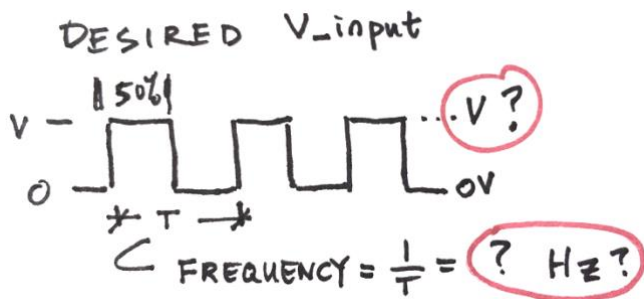

Once you have determined the conditions for the waveform, ► Run

Set up Scope to measure the response

Let's use Root Mean Square (RMS) Voltage for V_{out} . [Look up the difference](#) between different types of amplitude--dialogue with a neighbor, ninja or instructor about this question:



Sketch a graph that illustrated the difference between V-RMS, V-peak and V-peak2peak

(turn to one of your neighbors and compare your ideas)

In  , View>Measurements, Add>Defined Measurement, Choose AC RMS for your relevant channel.

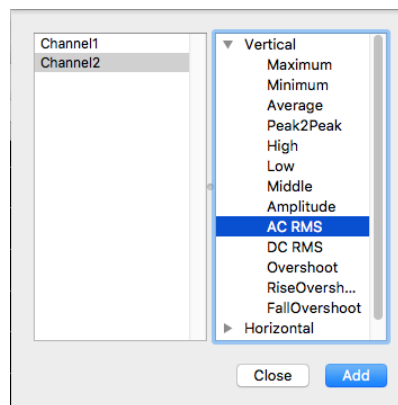
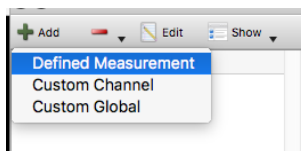
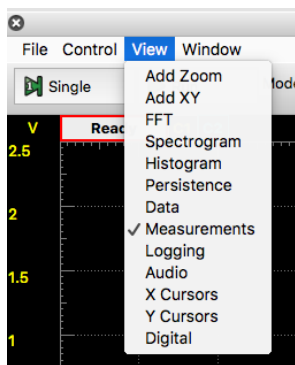

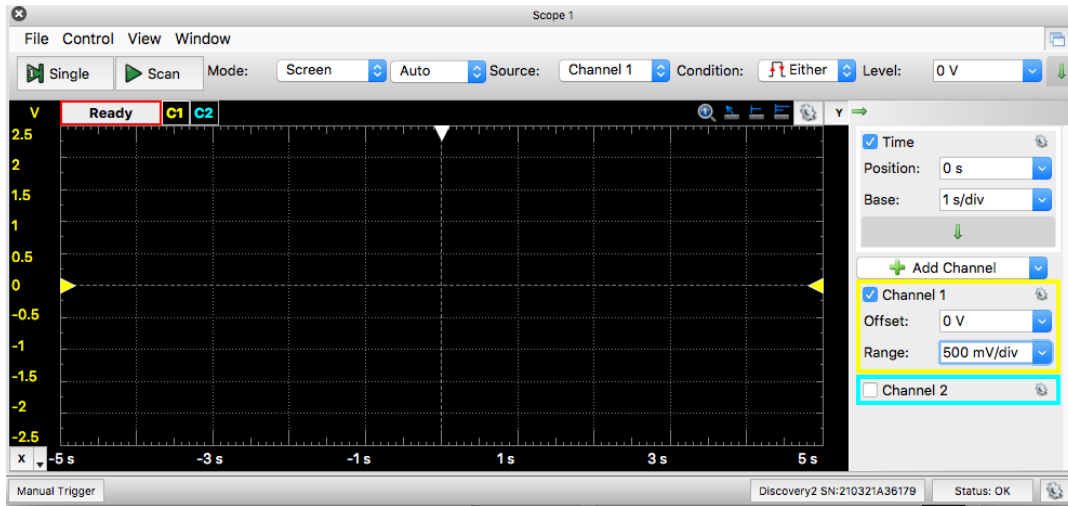

How can you adjust the time base to see 3-4 cycles?

Use Channel 2: What V range will allow you to see your input signal?

▶ Scan

Once you have recorded the measurement in the table below, replace the capacitor with a 100 pF capacitor. Note that the signal decays faster and the RMS voltage has decreased significantly. Mathematically, your sensor circuit has a large sensitivity, $\frac{dV}{dC}$.



How does this circuit feature help you with the goal of measuring humidity?

Capacitance value (R=10K)	Measured RMS Voltage amplitude
100 pF	
120 pF	
150 pF	
180 pF	
220 pF	

4. Plan data transformation



Generate the plot of the C v. V-RMS relationship for your lab report from your measured data.

In the next step you'll replace the capacitor with your %RH sensor. Make a plan of how you will use the data that you have to get the relative humidity from the voltage output of your sensor circuit.

You'll need the data sheet for the [humidity sensor](#).

5. Measure relative humidity

Replace the capacitor in your circuit with the [humidity sensor](#). Take the measurement of the RMS amplitude. From your calibration data, determine the relative humidity of the room.



Check your result to the relative humidity of the day (which you can check at www.weather.com).

6. Create and submit report



The results you need to include are highlighted in **RED** above. They include

- A plot of the measured voltage versus time data from the 1 volt square wave at 10 kHz into your circuit for your sensor.
- A sketch of the circuit you used and the Analog Discovery connections

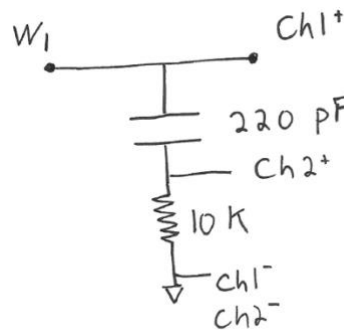
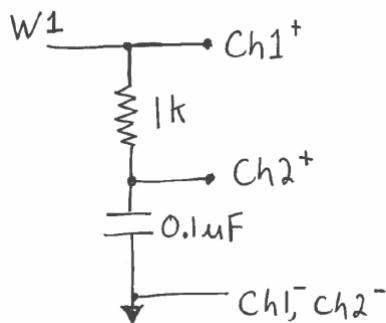

- Compare your measurement to the *analytical solution*. Note that the analytical solution will be the same for the CR circuit as the RC circuit in the book, just with a minor adjustment.
- Plot your calibration data for the capacitance meter that you created (i.e. a plot of the table data). Plot a reasonable linear fit, overlaid on the data points and report what your calibration equation is.
- Report on your results of using the capacitance meter you built to measure the relative humidity. Comment on the “official” humidity for the day whether your results make sense.

**analytical solution* = The value that you would get if you used the equations for an idealized RC or CR circuit.